



DUAL POWER OPERATIONAL AMPLIFIERS

- OUTPUT CURRENT TO 1 A
- OPERATES AT LOW VOLTAGES
- SINGLE OR SPLIT SUPPLY
- LARGE COMMON-MODE AND DIFFERENTIAL MODE RANGE
- GROUND COMPATIBLE INPUTS
- LOW SATURATION VOLTAGE
- THERMAL SHUTDOWN

DESCRIPTION

The L272 is a monolithic integrated circuits in Powerdip, Minidip and SO packages intended for use as power operational amplifiers in a wide range of applications including servo amplifiers and power supplies, compacts disc, VCR, etc.

The high gain and high output power capability provide superior performance whatever an operational amplifier/power booster combination is required.

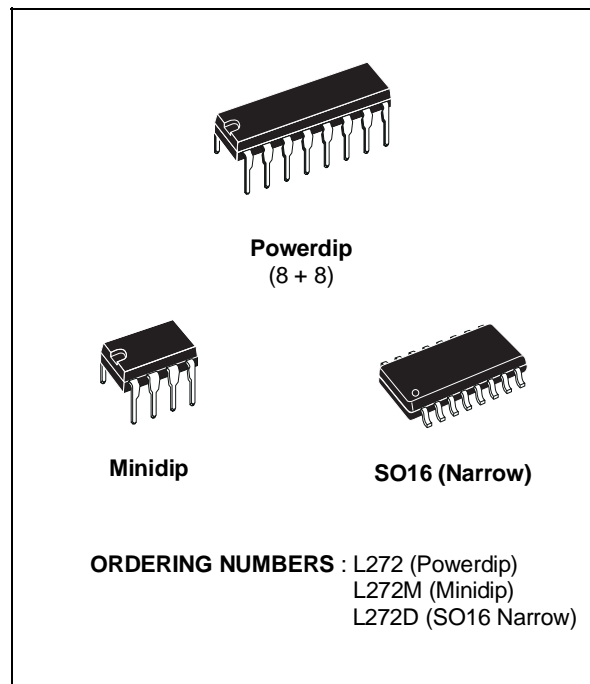

PIN CONNECTIONS (top view)

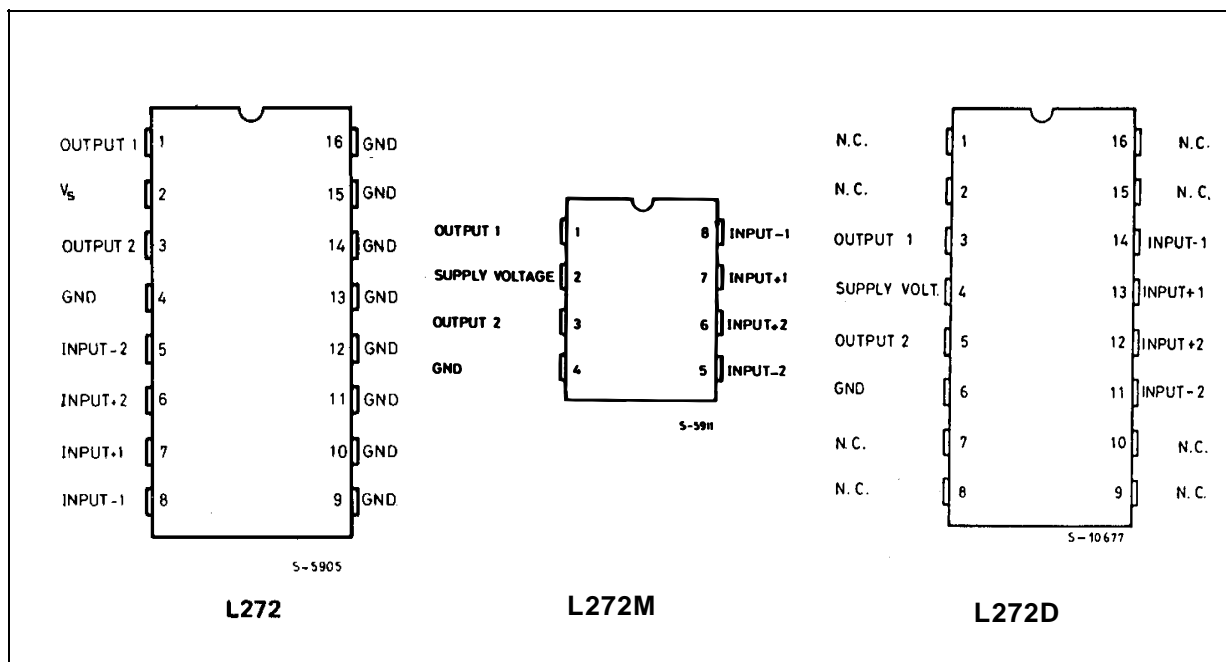

ABSOLUTE MAXIMUM RATINGS

Symbol	Parameter	Value	Unit
V_s	Supply Voltage	28	V
V_i	Input Voltage	V_s	
V_i	Differential Input Voltage	$\pm V_s$	
I_o	DC Output Current	1	A
I_p	Peak Output Current (non repetitive)	1.5	A
P_{tot}	Power Dissipation at: $T_{amb} = 80^\circ\text{C}$ (L272), $T_{amb} = 50^\circ\text{C}$ (L272M), $T_{case} = 90^\circ\text{C}$ (L272D) $T_{case} = 75^\circ\text{C}$ (L272)	1.2 5	W W
T_{op}	Operating Temperature Range (L272D)	- 40 to 85	$^\circ\text{C}$
T_{stg}, T_j	Storage and Junction Temperature	- 40 to 150	$^\circ\text{C}$

THERMAL DATA

Symbol	Parameter	Powerdip	SO16	Minidip	Unit
$R_{th\ j-case}$	Thermal Resistance Junction-pins Max.	15	-	* 70	$^\circ\text{C/W}$
$R_{th\ j-amb}$	Thermal Resistance Junction-ambient Max.	70	-	100	$^\circ\text{C/W}$
$R_{th\ j-alumina}$	Thermal Resistance Junction-alumina Max.	-	** 50	-	$^\circ\text{C/W}$

* Thermal resistance junction-pin 4

** Thermal resistance junctions-pins with the chip soldered on the middle of an alumina supporting substrate measuring 15x 20mm; 0.65mm thickness and infinite heatsink.

ELECTRICAL CHARACTERISTICS ($V_s = 24\text{V}$, $T_{amb} = 25^\circ\text{C}$ unless otherwise specified)

Symbol	Parameter	Test Conditions	Min.	Typ.	Max.	Unit
V_s	Supply Voltage		4		28	V
I_s	Quiescent Drain Current	$V_o = \frac{V_s}{2}$ $V_s = 24\text{V}$ $V_s = 12\text{V}$		8 7.5	12 11	mA mA
I_b	Input Bias Current			0.3	2.5	μA
V_{os}	Input Offset Voltage			15	60	mV
I_{os}	Input Offset Current			50	250	nA
SR	Slew Rate			1		V/ μs
B	Gain-bandwidth Product			350		kHz
R_i	Input Resistance		500			k Ω
G_v	O. L. Voltage Gain	$f = 100\text{Hz}$ $f = 1\text{kHz}$	60	70 50		dB dB
e_N	Input Noise Voltage	B = 20kHz		10		μV
I_N	Input Noise Current	B = 20kHz		200		pA
CRR	Common Mode Rejection	$f = 1\text{kHz}$	60	75		dB
SVR	Supply Voltage Rejection	$f = 100\text{Hz}$, $R_G = 10\text{k}\Omega$, $V_R = 0.5\text{V}$ $V_s = 24\text{V}$ $V_s = \pm 12\text{V}$ $V_s = \pm 6\text{V}$	54	70 62 56		dB
V_o	Output Voltage Swing	$I_p = 0.1\text{A}$ $I_p = 0.5\text{A}$	21	23 22.5		V V
C_s	Channel Separation	$f = 1\text{kHz}$; $R_L = 10\Omega$, $G_v = 30\text{dB}$ $V_s = 24\text{V}$ $V_s = \pm 6\text{V}$		60 60		dB
d	Distortion	$f = 1\text{kHz}$, $G_v = 3\text{dB}$, $V_s = 24\text{V}$, $R_L = \infty$		0.5		%
T_{sd}	Thermal Shutdown Junction Temperature			145		$^\circ\text{C}$

DIM.	mm			inch		
	MIN.	TYP.	MAX.	MIN.	TYP.	MAX.
A			1.75			0.069
a1	0.1		0.25	0.004		0.009
a2			1.6			0.063
b	0.35		0.46	0.014		0.018
b1	0.19		0.25	0.007		0.010
C		0.5			0.020	
c1	45° (typ.)					
D (1)	9.8		10	0.386		0.394
E	5.8		6.2	0.228		0.244
e		1.27			0.050	
e3		8.89			0.350	
F (1)	3.8		4	0.150		0.157
G	4.6		5.3	0.181		0.209
L	0.4		1.27	0.016		0.050
M			0.62			0.024
S	8° (max.)					

OUTLINE AND MECHANICAL DATA

Weight: 0.20gr

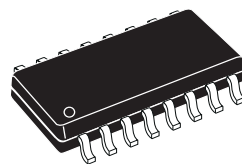

SO16 Narrow

(1) D and F do not include mold flash or protrusions. Mold flash or protrusions shall not exceed 0.15mm (.006inch).

